

DOVETAIL CORE ADVANTAGES

- Positive mechanically actuated Collapsible Core
- Collapse amount: 5% to 7% per side
- Eliminates costly Rack and Gear Systems
- Enables faster mold cycle times
- Patented Quick Lock helps cut service time
- Built-in center cooling channel
- Standard and custom sizes available

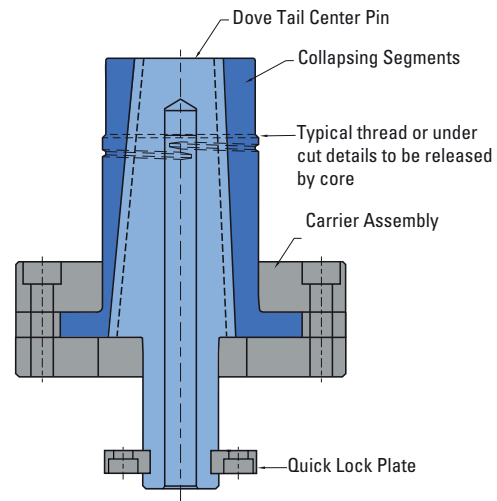

Simplified Mold Design Maximizes Cost Savings

The Collapsible Core DT Series provides a more compact and simplified solution to molding challenging internal undercut features such as o-ring grooves, slots and snap-fit designs. Available in four standard sizes and in customized sizes, the DT Collapsible Core Series eliminates the need for unscrewing mechanisms.

Dove Tail Collapsible Cores Enable Application Design Flexibility

- All standard DT Series Collapsible Cores offer 360 degree molding of threads or other undercut features
- Molded parts are not required to be closed at one end; they may be partially or completely open
- DME offers customized DT Cores with pre-machined part detail
- A variety of coatings and treatments are available
- For an engineering review, email your part drawing or application to dmeeu_specialprojects@milacron.com

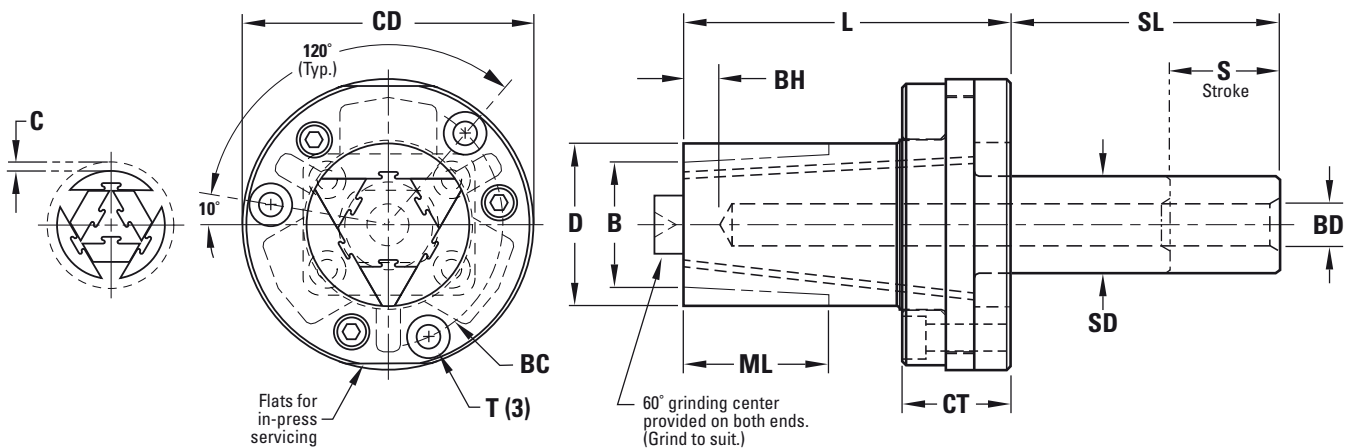

All dimensions and tolerances are in millimeters.

REF	D Maximum Outer Diameter	B Minimum Inner Diameter +3%/Side	ML Maximum Molding Length	C Maximum Collapse	CD Carrier Diameter	CT Carrier Assembly Thickness ± 0,05	L Core Length +0,1 -0,0	SL Shaft Length	SD Shaft Diameter +0,00 -0,02	BD Cooling Hole Diameter	BH Distance to Cooling Hole	BC Mounting Screw Bolt Circle	T Mounting Screws	S Maximum Collapse Stroke
DT18	21	17	22	1,1	53	21	60	60	16	6	6	40	M5 x 25	34
DT28	33	25	28	1,6	60	22	67	60	20	8	8	47	M5 x 25	38
DT38	42	33	43	2,1	76	28	85	60	25	10	10	60	M6 x 35	54
DT48	54	42	50	2,4	98	37	104	70	30	12	12	78	M8 x 40	62

