

Vectorform - Lifter System

VF-SS - VF-JS - VF-US

**VectorForm Lifter Sets include:**

- Holder bushing - VF-HB
- Guide Rod - VF-GR
- Guide Plate - VF-GP
- Slide Base:
- Standard - VF-SB,
- or Joint - VF-JB,
- or Universal - VF-UB



REF	Includes	Includes	Includes	Includes	Set
VF 06-SS	VF 06-HB	VF 06-GR	VF 06-GP	VF 06-SB	Standard
VF 08-SS	VF 08-HB	VF 08-GR	VF 08-GP	VF 08-SB	Standard
VF 10-SS	VF 10-HB	VF 10-GR	VF 10-GP	VF 10-SB	Standard
VF 13-SS	VF 13-HB	VF 13-GR	VF 13-GP	VF 13-SB	Standard
VF 16-SS	VF 16-HB	VF 16-GR	VF 16-GP	VF 16-SB	Standard
VF 20-SS	VF 20-HB	VF 20-GR	VF 20-GP	VF 20-SB	Standard
VF 06-JS	VF 06-HB	VF 06-GR	VF 06-GP	VF 06-SB	Joint
VF 08-JS	VF 08-HB	VF 08-GR	VF 08-GP	VF 08-SB	Joint
VF 10-JS	VF 10-HB	VF 10-GR	VF 10-GP	VF 10-SB	Joint
VF 13-JS	VF 13-HB	VF 13-GR	VF 13-GP	VF 13-SB	Joint

REF	Includes	Includes	Includes	Includes	Set
VF 16-JS	VF 16-HB	VF 16-GR	VF 16-GP	VF 16-SB	Joint
VF 20-JS	VF 20-HB	VF 20-GR	VF 20-GP	VF 20-SB	Joint
VF 06-US	VF 06-HB	VF 06-GR	VF 06-GP	VF 06-SB	Universal
VF 08-US	VF 08-HB	VF 08-GR	VF 08-GP	VF 08-SB	Universal
VF 10-US	VF 10-HB	VF 10-GR	VF 10-GP	VF 10-SB	Universal
VF 13-US	VF 13-HB	VF 13-GR	VF 13-GP	VF 13-SB	Universal
VF 16-US	VF 16-HB	VF 16-GR	VF 16-GP	VF 16-SB	Universal
VF 20-US	VF 20-HB	VF 20-GR	VF 20-GP	VF 20-SB	Universal

Features & Benefits

1. Moves freely at angles up to 30°. For angles greater than 30° please contact **DMETechnical Service** for design guidance.
2. Plate machining is significantly simplified as no diagonal hole machining is required in order to install the VectorForm Lifter System.
3. Maximum lifter angle is greatly improved with VectorForm Lifter System. Lifter cores may be installed at any given angle up to 30°.
4. The robust design and construction of the VectorForm Lifter System ensures that it is secure at any given ejector stroke regardless of angle used.
5. The compact design of the VectorForm Lifter System minimizes potential for interference with other components within the mold.
6. VectorForm Lifter System components are engineered for the common injection molding environment. No special coatings are necessary.
7. The lifter core assembly may be secured to the Slide Base in a variety of ways, maximizing design flexibility.
8. Maximizes allowable undercut space.

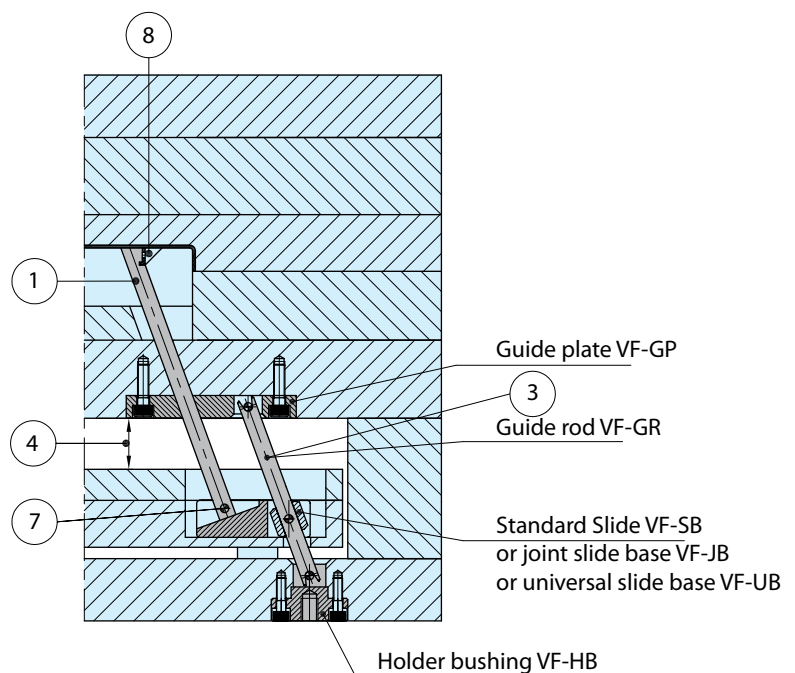

VF-SB

Standard Slide SB

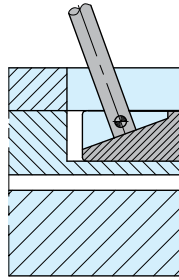

The Standard Slide Base is the most flexible and the most economical slide base. The Standard Slide Base can be custom machined by the mold builder to meet specialized application requirements. The Standard Slide Base is also the most robust slide base with respect to loads and forces.

VF-JB

Joint Slide Base JB

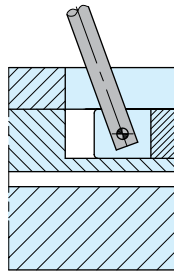

Joint Slide Base permits the lifter core assembly to be retained with a single pin.

VF-UB

Universal Slide Base UB

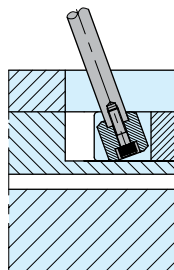

The universal Slide Base is similar to the Joint Slide Base, although the single pin is replaced by a universal joint which offers greater flexibility than the Joint Slide Base while still requiring only one screw to retain the lifter core assembly.

The lifter core (supplied by moldmaker) may be a single-piece component or an assembly of several components including a modified guide rod

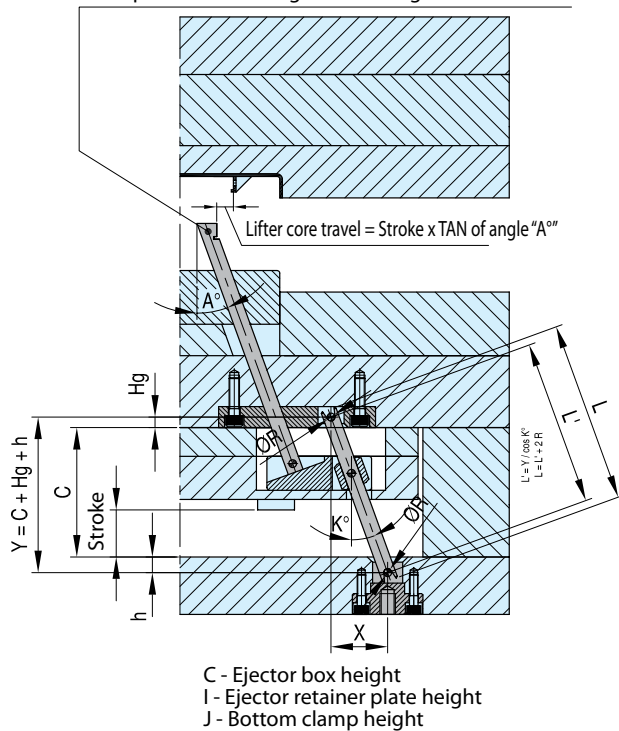

Locking Angles

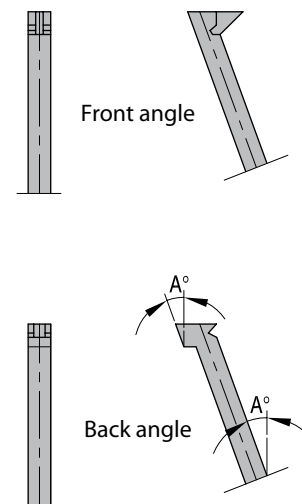

Installation instructions

1. General Installation

It is recommended that the VectorForm Lifter System be installed as shown. For each given VectorForm set, all components MUST be of the same size. However, separate sets of different sizes may be installed in the same mold. Actuation of VectorForm Lifter Systems can be accelerated or decelerated by an inclined sliding surface on the ejector plate and ejector retainer plate.

2. Angles

The VectorForm Lifter System may be used with angles ranging from 5° (min) to 30° (max). Deep undercuts in the molded part can be obtained by using a larger angle in the lifter core and by increasing the ejector plate stroke.

3. Lifter Core Guidance

The lifter core must have sufficient guidance in the tool. For multiple lifter cores installed in tandem in the tool, additional guidance in the core inserts is recommended. If resistance in actuation is great, an additional Guide Plate may be placed directly below the core insert.

4. Guided Ejection

Guided ejection is recommended for all designs.

5. Fit and Finish

Standard component dimensions and Rockwell hardness are provided in the component specifications section. Should the standard components need to be modified, additional performance can be obtained by treating

after finish machining (TiN coating, flash-chrome, etc.).

Component installations can be fitted to suit. Ensure a loose fit on the Holder Bushing and Guide Plate installation. Ensure a precise fit between the lifter core and Guide Plate. The Holder Bushing will automatically align prior to bolting the bushing to the clamp plate. Lubrication is not generally required nor recommended. If lubrication is used, it should be low-viscosity.

6. Locking Angles/ Component Back-up

Locking angles may be designed to provide a locking surface to counter against molding pressure. A block construction using a square lifter core can also allow the resin pressure to be backed up by the core insert. If the axial load acting on the lifter core exceeds the limit allowed for the slide base pin (used in VF-JB and VF-UB Slide Bases), use a Standard (VF-SB) Slide Base and back the lifter core on the slide by machining a ledge that is perpendicular to the axis of the lifter core. The lifter core must then seat firmly against the angled face of the Slide Base.

7. Non-Standard Shapes/Materials

Lifter core blocks may be machined to any desired shape and size, provided the chosen number and size of the VectorForm Lifter System core standard components will support the lifter core blocks. Lifter core blocks are to be supplied by the moldmaker.

VF-SB

Standard Slide Base

Mat.: DIN 1.7225/30-33 HRC

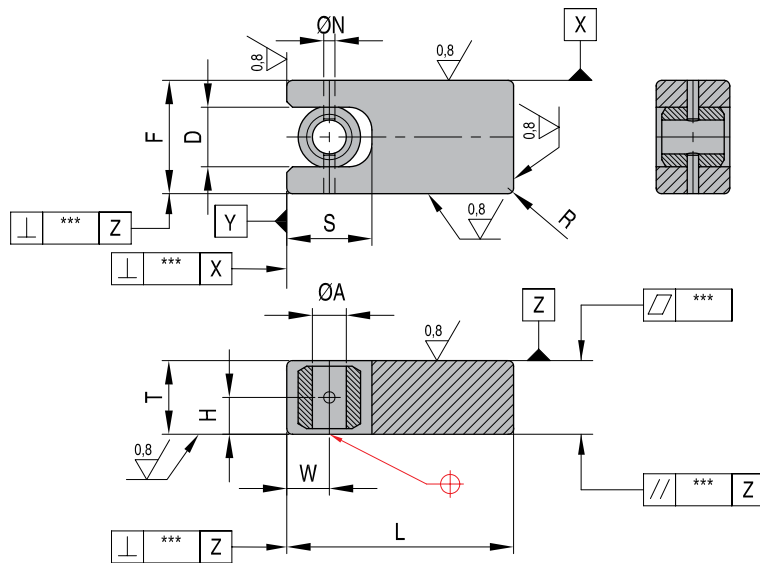

**Additional Machining:**  
Retaining bolt installation on lifter core rod or assembly.  
**Heat Treatment:**  
Gas nitriding is permissible after additional machining has been performed.

REF	A	L	F	T	D	H	W	S	N	R			
VF 06 SB	6	40 <sup>0</sup> <sub>-0,10</sub>	20 <sup>0</sup> <sub>-0,02</sub>	13 <sup>0</sup> <sub>-0,02</sub>	10,5	6,5	7,5	15	2	1	0,010	0,01-0,02	0,02
VF 08 SB	8	50 <sup>0</sup> <sub>-0,10</sub>	25 <sup>0</sup> <sub>-0,02</sub>	15 <sup>0</sup> <sub>-0,02</sub>	13,5	7,5	10,0	20	3	1	0,010	0,01-0,02	0,02
VF 10 SB	10	60 <sup>0</sup> <sub>-0,20</sub>	32 <sup>0</sup> <sub>-0,03</sub>	20 <sup>0</sup> <sub>-0,03</sub>	17,0	10,0	12,5	25	4	2	0,015	0,02-0,03	0,03
VF 13 SB	13	80 <sup>0</sup> <sub>-0,20</sub>	40 <sup>0</sup> <sub>-0,03</sub>	25 <sup>0</sup> <sub>-0,03</sub>	22,0	12,5	15,0	30	5	2	0,015	0,02-0,03	0,03
VF 16 SB	16	100 <sup>0</sup> <sub>-0,30</sub>	50 <sup>0</sup> <sub>-0,05</sub>	30 <sup>0</sup> <sub>-0,05</sub>	27,0	15,0	20,0	40	6	3	0,020	0,02-0,05	0,05
VF 20 SB	20	130 <sup>0</sup> <sub>-0,30</sub>	60 <sup>0</sup> <sub>-0,05</sub>	40 <sup>0</sup> <sub>-0,05</sub>	33,0	20,0	25,0	50	7	3	0,020	0,02-0,05	0,05

VF-JB

Joint Slide Base

Mat.: DIN 1.7225/DIN 1.1213/60-66HRC

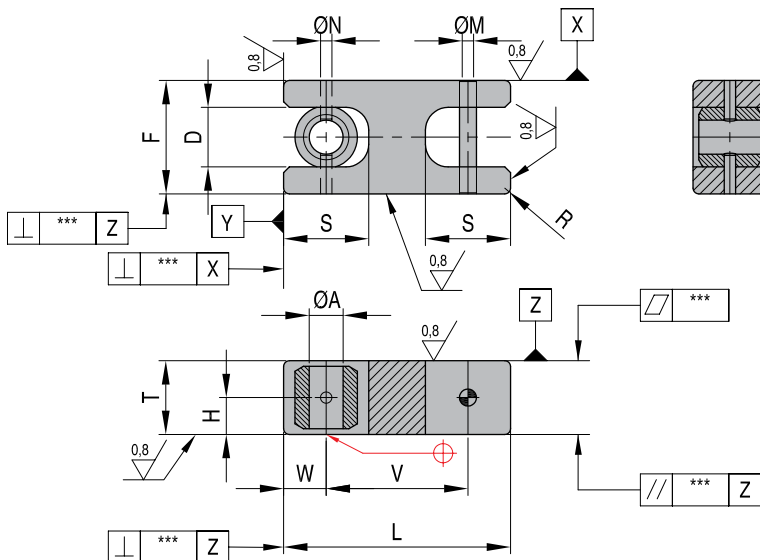

**Attachment:** Joint Pin  
**Heat Treatment:** Gas nitriding is permissible; during nitriding, use a pin finer (-0.01) than the attached joint pin.  
**Joint Pin material:**  
DIN1.1213  
**Hardness:** HRC 60-66  
**Tempering temperature:** 600°C

REF	A	L	F	T	D	H	W	S	V	N	M	R			
VF 06 JB	6	40 <sup>0</sup> <sub>-0,10</sub>	20 <sup>0</sup> <sub>-0,02</sub>	13 <sup>0</sup> <sub>-0,02</sub>	10,5	6,5	7,5	15	25	2	3	1	0,01	0,01-0,02	0,02
VF 08 JB	8	50 <sup>0</sup> <sub>-0,10</sub>	25 <sup>0</sup> <sub>-0,02</sub>	15 <sup>0</sup> <sub>-0,02</sub>	13,5	7,5	10	20	30	3	4	1	0,01	0,01-0,02	0,02
VF 10 JB	10	60 <sup>0</sup> <sub>-0,20</sub>	32 <sup>0</sup> <sub>-0,03</sub>	20 <sup>0</sup> <sub>-0,03</sub>	17	10	12,5	25	35	4	5	2	0,015	0,02-0,03	0,03
VF 13 JB	13	80 <sup>0</sup> <sub>-0,20</sub>	40 <sup>0</sup> <sub>-0,03</sub>	25 <sup>0</sup> <sub>-0,03</sub>	22	12,5	15	30	50	5	6	2	0,015	0,02-0,03	0,03
VF 16 JB	16	100 <sup>0</sup> <sub>-0,30</sub>	50 <sup>0</sup> <sub>-0,05</sub>	30 <sup>0</sup> <sub>-0,05</sub>	27	15	20	40	60	6	8	3	0,02	0,02-0,05	0,05
VF 20 JB	20	130 <sup>0</sup> <sub>-0,30</sub>	60 <sup>0</sup> <sub>-0,05</sub>	40 <sup>0</sup> <sub>-0,05</sub>	33	20	25	50	80	7	10	3	0,02	0,02-0,05	0,05

Universal Slide Base

Mat.: DIN 1.7225/30-33 HRC

VF-UB

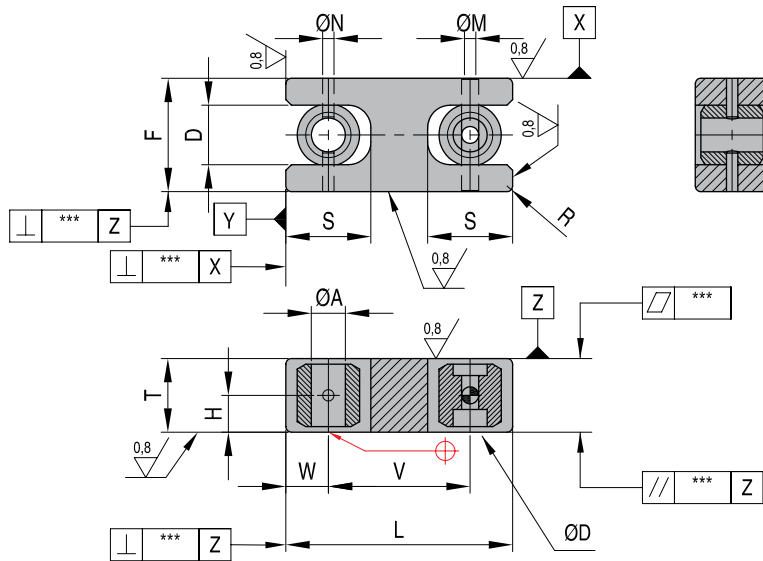

**Attachment:** None  
**Heat Treatment:**  
Nitriding is permissible.

REF	A	L	F	T	D	H	W	S	V	N	M	ØD	R	⊓	//	⊥
VF 06 UB	6	40 <sup>0</sup> <sub>-0,10</sub>	20 <sup>0</sup> <sub>-0,02</sub>	13 <sup>0</sup> <sub>-0,02</sub>	10,5	6,5	7,5	15	25	2	3	M3x10	1	0,010	0,01-0,02	0,02
VF 08 UB	8	50 <sup>0</sup> <sub>-0,10</sub>	25 <sup>0</sup> <sub>-0,02</sub>	15 <sup>0</sup> <sub>-0,02</sub>	13,5	7,5	10,0	20	30	3	4	M4x12	1	0,010	0,01-0,02	0,02
VF 10 UB	10	60 <sup>0</sup> <sub>-0,20</sub>	32 <sup>0</sup> <sub>-0,03</sub>	20 <sup>0</sup> <sub>-0,03</sub>	17,0	10,0	12,5	25	35	4	5	M5x15	2	0,015	0,02-0,03	0,03
VF 13 UB	13	80 <sup>0</sup> <sub>-0,20</sub>	40 <sup>0</sup> <sub>-0,03</sub>	25 <sup>0</sup> <sub>-0,03</sub>	22,0	12,5	15,0	30	50	5	6	M6x20	2	0,015	0,02-0,03	0,03
VF 16 UB	16	100 <sup>0</sup> <sub>-0,30</sub>	50 <sup>0</sup> <sub>-0,05</sub>	30 <sup>0</sup> <sub>-0,05</sub>	27,0	15,0	20,0	40	60	6	8	M8x25	3	0,020	0,02-0,05	0,05
VF 20 UB	20	130 <sup>0</sup> <sub>-0,30</sub>	60 <sup>0</sup> <sub>-0,05</sub>	40 <sup>0</sup> <sub>-0,05</sub>	33,0	20,0	25,0	50	80	7	10	M10x35	3	0,020	0,02-0,05	0,05

Additional machining - Installation classification

VF-SB VF-JB VF-UB

\*These are retention grooves used to retain the slide base in the ejector plates. They need to be machined by the customer.

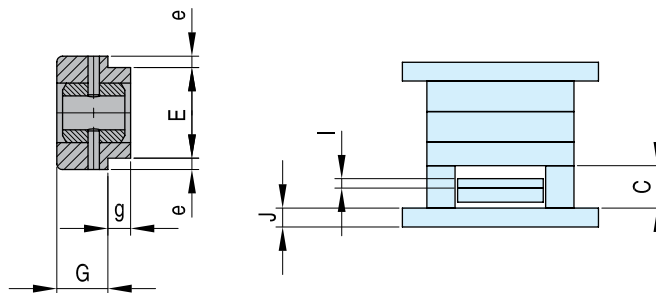

REF	E	e	G	g	I	J	C
VF 06 SB/JB/UB	16	2,0	9	4	13	20	50-120
VF 06 SB/JB/UB	20	2,5	11	4	15	25	50-150
VF 06 SB/JB/UB	26	3,0	14	6	20	30	70-200
VF 06 SB/JB/UB	33	3,5	17	8	25	35	100-250
VF 06 SB/JB/UB	42	4,0	22	8	30	40	120-300
VF 06 SB/JB/UB	50	5,0	28	12	35	50	120-400

VF-GR

Guide rod

Mat.: DIN 1.3505 - 58-60HRC

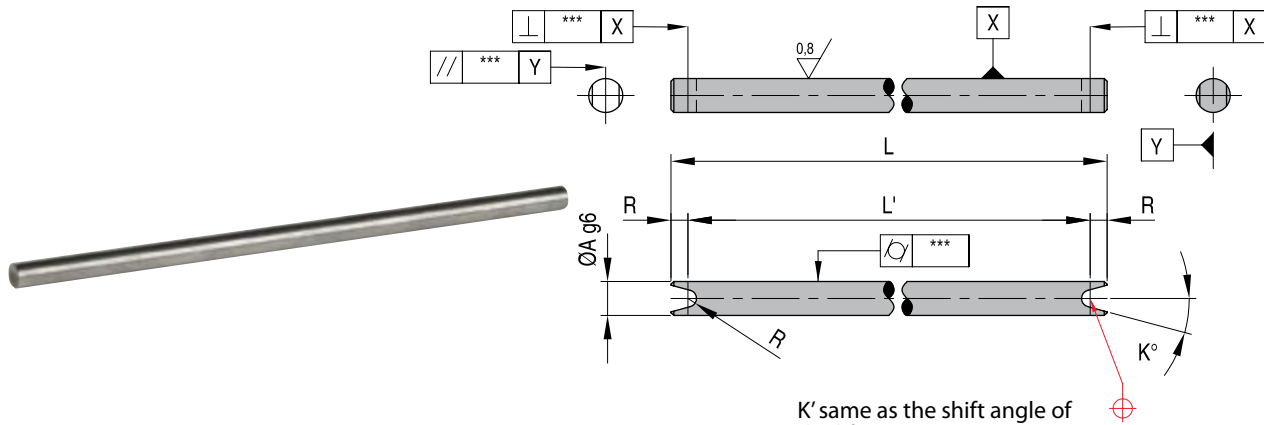

K' same as the shift angle of the lifter core (30°)

**Note:** Moldmaker to add grooves and chamfers per specification shown.

REF	A	L	L' = L-2R	R	$\parallel$ // $\perp$
VF 06 GR	6	150	148 <sup>-0,05</sup> <sub>-0,1</sub>	1,0 <sup>+0,02</sup> <sub>0</sub>	0,02
VF 08 GR	8	190	187 <sup>-0,05</sup> <sub>-0,1</sub>	1,5 <sup>+0,02</sup> <sub>0</sub>	0,02
VF 10 GR	10	250	246 <sup>-0,1</sup> <sub>-0,2</sub>	2,0 <sup>+0,03</sup> <sub>0</sub>	0,03
VF 13 GR	13	310	305 <sup>-0,1</sup> <sub>-0,2</sub>	2,5 <sup>+0,03</sup> <sub>0</sub>	0,03
VF 16 GR	16	370	364 <sup>-0,2</sup> <sub>-0,4</sub>	3,0 <sup>+0,05</sup> <sub>0</sub>	0,05
VF 20 GR	20	500	493 <sup>-0,2</sup> <sub>-0,4</sub>	3,5 <sup>+0,05</sup> <sub>0</sub>	0,05

VF-GP

Guide plate

Mat.: 1.1213 - 22-25HRC

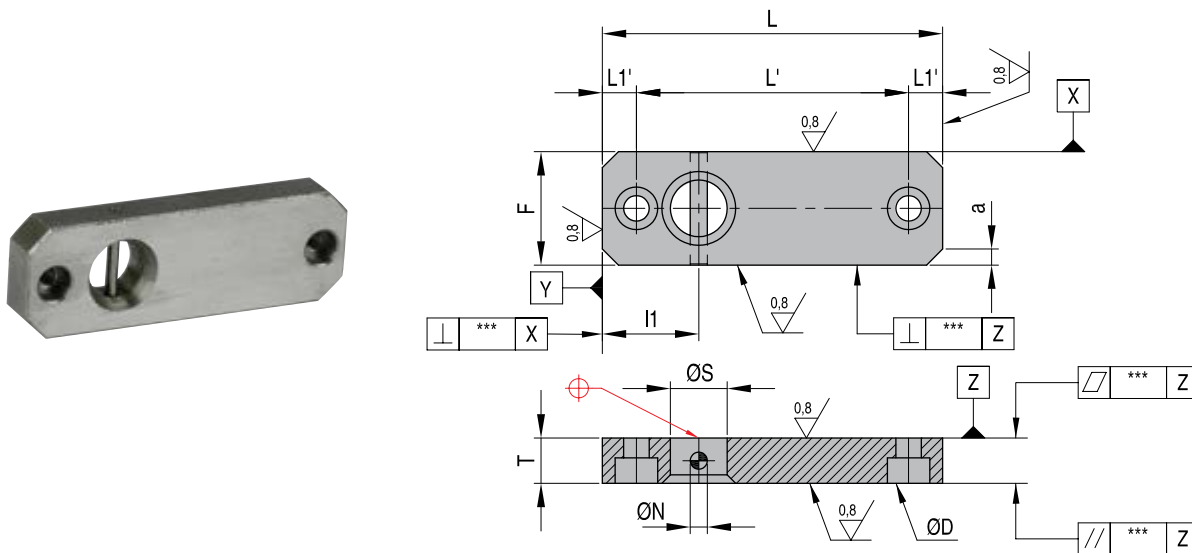

REF	L	F	T	S	N	L'	L1'	L1	ØD	//	$\perp$	$\varnothing$	a
VF 06 GP	60 <sup>0</sup> <sub>-0,04</sub>	20 <sup>0</sup> <sub>-0,02</sub>	8 <sup>0</sup> <sub>-0,02</sub>	10	2	50	5	17,5	M3x10	0,01	0,01-0,02	0,01-0,02	4,0
VF 08 GP	70 <sup>0</sup> <sub>-0,04</sub>	25 <sup>0</sup> <sub>-0,02</sub>	10 <sup>0</sup> <sub>-0,02</sub>	13	3	60	5	20	M4x12	0,01			5,0
VF 10 GP	90 <sup>0</sup> <sub>-0,06</sub>	32 <sup>0</sup> <sub>-0,03</sub>	12 <sup>0</sup> <sub>-0,03</sub>	16	4	75	7,5	25	M5x15	0,01	0,02-0,03	0,02-0,03	6,0
VF 13 GP	120 <sup>0</sup> <sub>-0,06</sub>	40 <sup>0</sup> <sub>-0,03</sub>	15 <sup>0</sup> <sub>-0,03</sub>	20	5	105	7,5	30	M6x12	0,01			7,5
VF 16 GP	150 <sup>0</sup> <sub>-0,1</sub>	50 <sup>0</sup> <sub>-0,05</sub>	20 <sup>0</sup> <sub>-0,05</sub>	25	6	130	10	40	M8x25	0,01	0,02-0,05	0,02-0,05	10,0
VF 20 GP	180 <sup>0</sup> <sub>-0,1</sub>	60 <sup>0</sup> <sub>-0,05</sub>	25 <sup>0</sup> <sub>-0,05</sub>	30	7	155	12,5	45	M10x30	0,01			12,2

Holder bushing

Mat.: 1.1213 - 15-20HRC

VF-HB

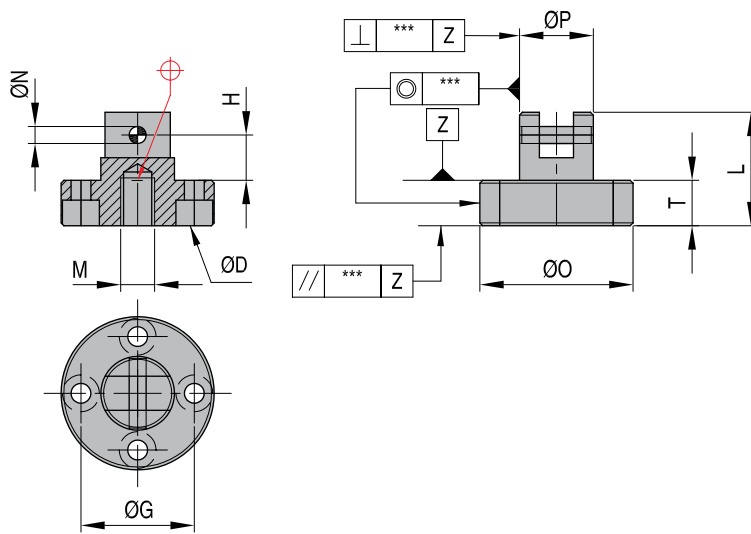

REF	P	L	O	T	G	ØD	H	M	N	//	⊥	○
<b>VF 06 HB</b>	13 <sup>0</sup> <sub>-0,05</sub>	20 <sup>-0,1</sup> <sub>-0,2</sub>	27 <sup>0</sup> <sub>-0,2</sub>	8 <sup>-0,1</sup> <sub>-0,2</sub>	19	M3x10	8,0	M3x6	2	0,05	0,04	0,02
<b>VF 08 HB</b>	16 <sup>0</sup> <sub>-0,05</sub>	25 <sup>-0,1</sup> <sub>-0,2</sub>	34 <sup>0</sup> <sub>-0,2</sub>	10 <sup>-0,1</sup> <sub>-0,2</sub>	24	M4x12	10,0	M4x8	3	0,05	0,04	0,02
<b>VF 10 HB</b>	20 <sup>0</sup> <sub>-0,07</sub>	30 <sup>-0,1</sup> <sub>-0,3</sub>	42 <sup>0</sup> <sub>-0,3</sub>	12 <sup>-0,1</sup> <sub>-0,3</sub>	30	M5x15	12,0	M5x10	4	0,07	0,06	0,03
<b>VF 13 HB</b>	25 <sup>0</sup> <sub>-0,07</sub>	35 <sup>-0,1</sup> <sub>-0,3</sub>	51 <sup>0</sup> <sub>-0,3</sub>	15 <sup>-0,1</sup> <sub>-0,3</sub>	37	M6x12	12,5	M6x12	5	0,07	0,06	0,03
<b>VF 16 HB</b>	30 <sup>0</sup> <sub>-0,1</sub>	40 <sup>-0,1</sup> <sub>-0,5</sub>	65 <sup>0</sup> <sub>-0,5</sub>	20 <sup>-0,1</sup> <sub>-0,5</sub>	47	M8x25	12,0	M8x15	6	0,10	0,10	0,05
<b>VF 20 HB</b>	40 <sup>0</sup> <sub>-0,1</sub>	50 <sup>-0,1</sup> <sub>-0,5</sub>	80 <sup>0</sup> <sub>-0,5</sub>	25 <sup>-0,1</sup> <sub>-0,5</sub>	58	M10x30	15,5	M10x20	7	0,10	0,10	0,05